

**Desalination heat exchanger**

Heat recycling from the desalination condensate at CERTUSS steam generators and heating of the boiler feed water to be supplied in the feed water tank.



## Desalination heat exchanger at a glance

### CERTUSS desalination heat exchanger

- + Specially for use at CERTUSS steam generators
- + Heat exchanger with buffer storage vessel for the boiler feed water to be filled in the feed water tank
- + Replaceable stainless-steel tube bundle.

The condensate from the steam dryer or steam distributor is transported via the tube bundle of the heat exchanger to the mixing heat exchanger or channel. In counterflow the cold feed water flows from the water treatment system via the tank of the heat exchanger into the feed water tank. In the process the energy from the condensate is transported to the heating of the feed water. At the same time the cooling water quantity in the waste-water mixing heat exchanger is reduced by the colder desalination condensate.

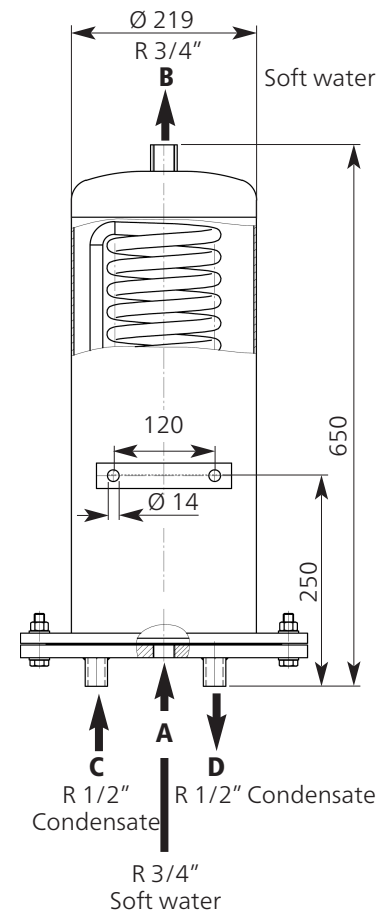

Technical Data		
Volume tank	liter	17
Pressure tank	max. bar	0,5
Volume piping system	liter	0,8
Pressure piping system	max. bar	10
Heating surface piping system	m <sup>2</sup>	0,75
Flow quantity condensate	liter/h	150
Flow quantity feed water	liter/h	2000
Material / Piping system	Stainless-steel 1.4301	
Mounting position	Vertical, condensate connections at bottom	
Exchange output*	to kW	15

\* Output depends on the throughput volume of the condensate and of the feed water.  
Dimensions, weights and other values rounded up or down. Pressure data are overpressure values.

We reserve the right to make technical modifications.

